

# Airpura

AIR PURIFIERS

# R600

All Purpose

## *Remove Dangerous Airborne Chemicals and Particles From Your Indoor Air*

The EPA has stated that indoor air quality is now the number one environmental health concern.

The R600's powerful 560 CFM impeller draws air through an 18lb Carbon Bed and True HEPA filter to clean your indoor air and help protect you and your family from the health hazards of living in polluted indoor air.



### *Poor quality indoor air may contain*

#### **Particles**

Pet dander	Pollen	Mold spores
Dust mites	Droplets	Asbestos
		Tobacco Smoke

#### **Airborne Chemicals**

Formaldehyde	Radon	Methylene Chloride
Ammonia	Glues	Mold Mycotoxins
Benzene	Pesticides	Perchloroethylene

### *Symptoms associated with poor quality indoor air*

Allergies	Runny noses	Damage to liver,
Asthma	Eye irritations	kidney and central
Dry throats	Nausea	nervous system
Wheezing	Loss of coordination	
Coughing	Cancers	

## ***The Airpura R600***

Available in  
White / Black / Cream

The Airpura Limited Warranty  
5 years parts 10 years labor

### **Long Lasting Filters**

Carbon filters typically last up to 2 years depending on use

Hepa filters typically last 5 years in regular use.

Pre-filters can be vacuumed from the exterior of the unit and should be changed every 12 months depending on use

***Feel the Difference Breathing Clean Air Makes to Your Health***

## Technical Specifications

**Odors, airborne chemical control**  
18 lbs activated carbon  
13" x 13" x 9"

**Carbon bed**  
2" deep x 570 sq" surface

**Particle removal**  
40 sq ft true HEPA  
(Measured 1 side only)  
10 pleats per inch  
Pleats warm rolled with separators

**Air Flow 560 cfm**  
More cfm than any other home unit available

**Pre-filter**  
570 sq in x 1 in

**Housing**  
Powder coat steel

**Size**  
23" x 15"

**Weight**  
45lbs total

**Voltage Options**  
115 or 220 volts

**Watts**  
120 on high 40 on low

**Sound Level**  
28.1 db on low (at 6 feet)  
62.3 db on high (560 cfm)  
(Room Level 25.1)

**ETL Certified**  
Conforms to  
CSA C22.2 no 113  
ANSI / UL 507

Your Airpura Dealer

## Unique Features

- Pressure seal Airpura's unique pressure seal on the filter chamber ensures that all of the dirty air passes through the filters. Other systems allow leakage and do not achieve the 99.97% HEPA filtration rating
- Felt gaskets seal the filter chamber. Maximize filtration with no rubber off-gassing found with other filters
- All metal housing ensures no plastic vapors are emitted
- Backward curved motorized impeller eliminates the vibrations and noise associated with older motor and shaft set ups
- Variable speed motor lets you choose your ideal level of filtration
- Motor out of the air flow. Most air purifiers blow the clean air over the motor and pick up fresh impurities
- Unimpeded airflow simple and direct internal airflow avoids the air turbulence, inefficiency and noise associated with more convoluted systems
- Separate electrical parts chamber prevents any off gassing from capacitors, condensers or switches.
- Perforated steel exterior offers both a softer appearance and 360 degree air intake and distribution.
- Separately changeable filters The Hepa and carbon filters can be changed separately so you only change them when appropriate and save operating costs

## High Efficiency Filtration

**Cleanable pre-filter**  
Vacuum through grill and change every 12 months

**2 MicroSuppress filters**  
Suppress bacteria and viruses

**18 lbs 2" Carbon bed**  
Absorbs airborne chemicals noxious gases and odors

**HEPA filter**  
Traps 99.97% of particles as small as 0.3 microns

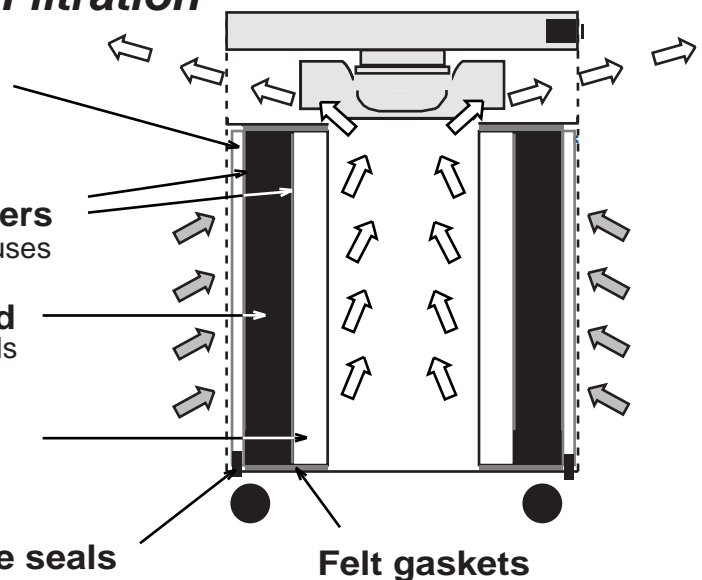

### True HEPA Filters

Developed by the atomic energy commission to filter radio active particles as small as 0.3 microns

### Activated Carbon

Used in water filtration and in military gas masks, it can adsorb 60 % of it's own weight of airborne chemicals

**Safe effective air purification for home, office and workplace**